



*It's All about Building a Better Product for Our Clients!*

**J&M Fluidics, Inc.**  
851 Tech Drive  
Telford, PA 18969  
**Toll-Free: (888) 539-1731**  
**Fax: 267-203-8786**

**Model: IEZAT22D**

**Split-System, Air-Cooled 22 Ton Chiller**

**with Stainless Steel Tank**



**STANDARD ON ALL J&M MODELS:**  
Pentra Microsmart, Programmable Logic Controller (PLC)  
with HMI Touch Screen Display.

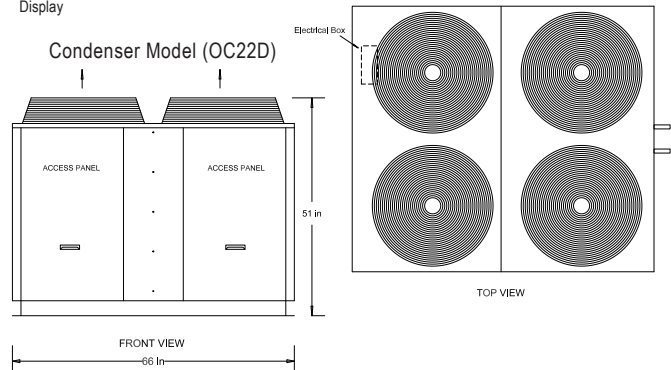

**OC Refrigerant Connections:** Discharge Line- 1 1/8" (2), Liquid Line- 5/8" (2)

**Standard Features:**

- ETL listed to UL1995 & CAN/CSA C22.2 No. 236-11, 4th edition, 10/14/2011
- Single point power connection
- Pentra Microsmart, Programmable Logic Controller (PLC) with easy to use HMI touch screen display
- **STAINLESS STEEL**, brazed plate evaporator
- Scroll compressor with crankcase heater
- Suction accumulator
- Water flow switch
- Hot gas by-pass capacity control
- 24V control transformer
- Direct drive condenser fan motor
- Rust resistant, high CFM, aluminum condenser fan blade
- Condenser(s): copper tube/ aluminum fin
- Compressor motor contactor
- Condenser motor and control circuit fusing
- **Painted (Powder Coated), galvanized sheet metal cabinet**
- 1/2" insulation on all water and Low pressure refrigerant lines
- Liquid line drier, sight glass, solenoid, TXV
- Complete refrigerant charge from factory
- **Factory Performance Test prior to shipment**



*Easy to Use Touch Screen Display on ALL J&M Chiller Models*

**Tank**

- **STAINLESS STEEL** storage tank with 1/2 inch insulation
- Fused, **STAINLESS STEEL** re-circulation pump for tank operation with ball valve and cleanable strainer
- Tank pressure relief valve, vent and drain hose bibs

**Options:**

- Remote Idec touchscreen control panel
- Industrial VPN Router
- 5 Port Ethernet Switch
- BacNet Gateway
- Process Pump VFD Controller
- VFD Compressor Control on primary compressor
- 4 year extended compressor warranty
- Casters (factory mounted)
- 115 volt (rain tight) service outlet
- Non Fused Disconnect
- Phase Monitor, line voltage monitor offering protection against phase loss/reversal, unbalance and hi/lo voltage
- Compressor fusing
- Compressor Sound Cover
- Factory installed evaporator heat tape freeze protection
- Low flow by-pass valve
- Fused, **STAINLESS STEEL** process pump
- Dual system pump with manual changeover (some models)
- Dual system pump with auto changeover (some models)
- Pump suction isolation valve
- Water pressure gauge set
- Water Flow Meter
- Auto city water changeover panel with filter
- Door Mounted HMI with weather proof cover

**Tank Options**

- Storage tank sight glass
- Tank low liquid level indicator with dry contacts
- Auto Tank Fill

**J&M FLUIDICS, INC. – PRODUCT DATA SHEET**



*It's All about Building a Better Product for Our Clients!*

**J&M Fluidics, Inc.**

851 Tech Drive  
Telford, PA 18969

Toll-Free: (888) 539-1731

Fax: 267-203-8786

# Model: IEZAT22D

## Split-System, Air-Cooled 22 Ton Chiller

### Product Dimensional Drawing

© Property of J&M Fluidics, Inc.

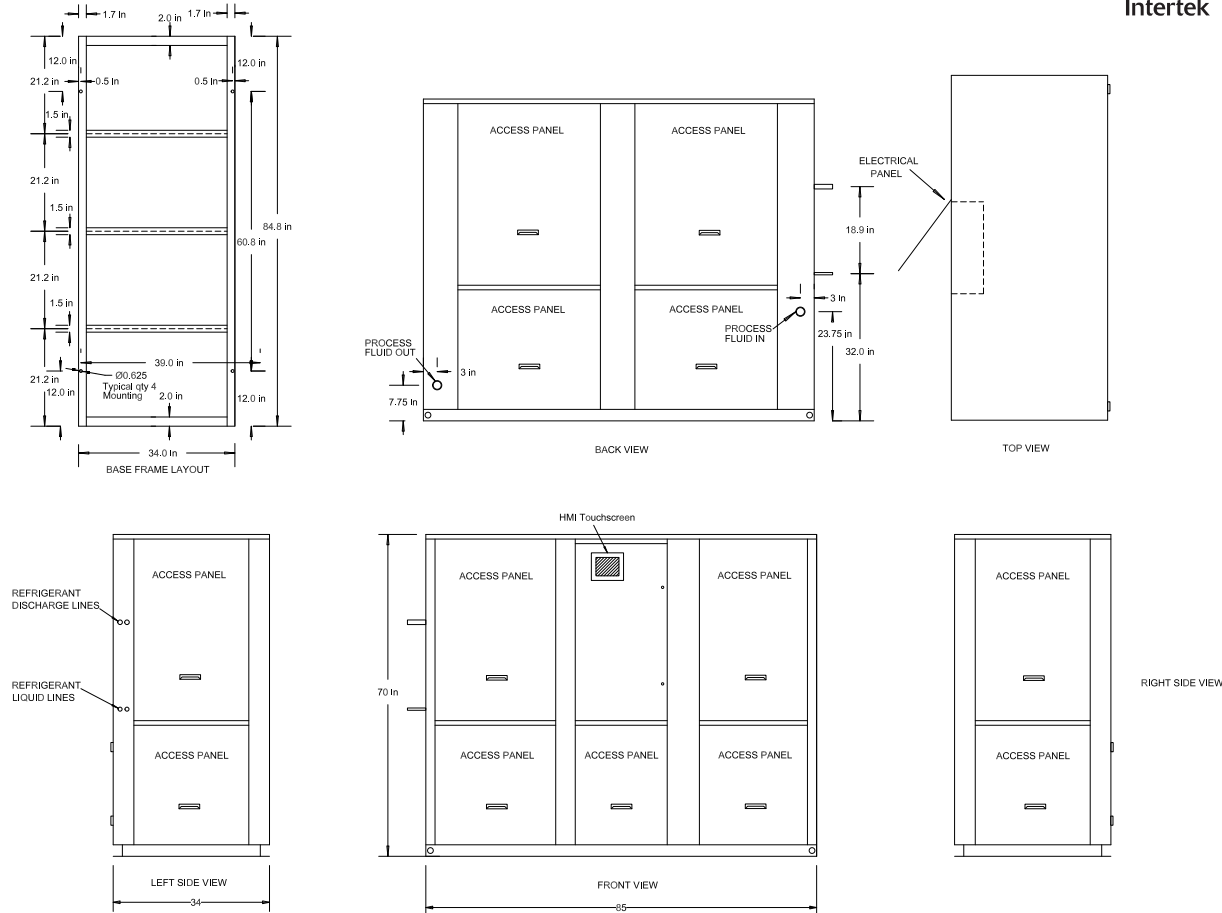

### Dimensional & Electrical Table (Dual Circuit)

Chiller Models	Length Inches	Width Inches	Height Inches	Power			Compressor		RLA ea.	LRA ea.	Fan Motor		Recirculation Pump FLA	MCA	M.O.P	Reservoir Gal.	Chiller Fluid Conn.	Weight LBS.	Condenser Selection				
				Voltage	Phase	Freq.	Qty.	HP			Qty.	FLA.											
IEZAT22DF5	85	34	70	208/230V	3	60Hz	2	13	49.4	300	3.8	5.6	125	150	120	1.5" FPT	2100	0C22D					
IEZAT22DH5				460V	3	60Hz			23.1	150									4	1.5	2.8	60	70
IEZAT22DI5				575V	3	60Hz			19.2	109									1.72	2.3	60	70	

\* = Requires the use of glycol. **Capacity Table (Refrigerant R407C)**

Model	Compressor	LWT °F	80°F			90°F			95°F			100°F			105°F		
			TONS	KW	EER	TONS	KW	EER	TONS	KW	EER	TONS	KW	EER	TONS	KW	EER
22D	ZB95KCE	42.0	20.2	18.0	12.0	18.9	19.8	10.5	18.3	20.8	9.8	17.6	21.8	9.2	16.9	23.0	8.5
		44.0	21.2	18.2	12.3	19.8	20.0	10.7	<b>19.2</b>	<b>21.0</b>	<b>10.0</b>	18.4	22.0	9.4	17.8	23.2	8.8
		45.0	21.6	18.2	12.5	20.3	20.1	10.9	19.6	21.1	10.2	18.9	22.2	9.6	18.2	23.3	8.9
		50.0	24.2	18.8	13.1	22.8	20.6	11.6	22.1	21.6	10.8	21.3	22.6	10.2	20.5	23.7	9.5

- Capacities on this chart are based on refrigerant R407C. Lower leaving water or low ambient can require the use of a glycol solution or other fluid blends. These solutions affect unit capacities. Please consult the factory on these or other special fluids.
- KW input is for compressor(s) only.
- EER = Energy Efficiency Ratio (BTU/watt-hour). Power inputs include compressor (s), condenser fan motor (s) and control power.