



*It's All about Building a
Better Product for Our Clients!*

J&M Fluidics, Inc.
851 Tech Drive
Telford, PA 18969
Toll-Free: (888) 539-1731
Fax: 267-203-8786

Model: PZA15D

Packaged Air-Cooled 15 Ton Chiller

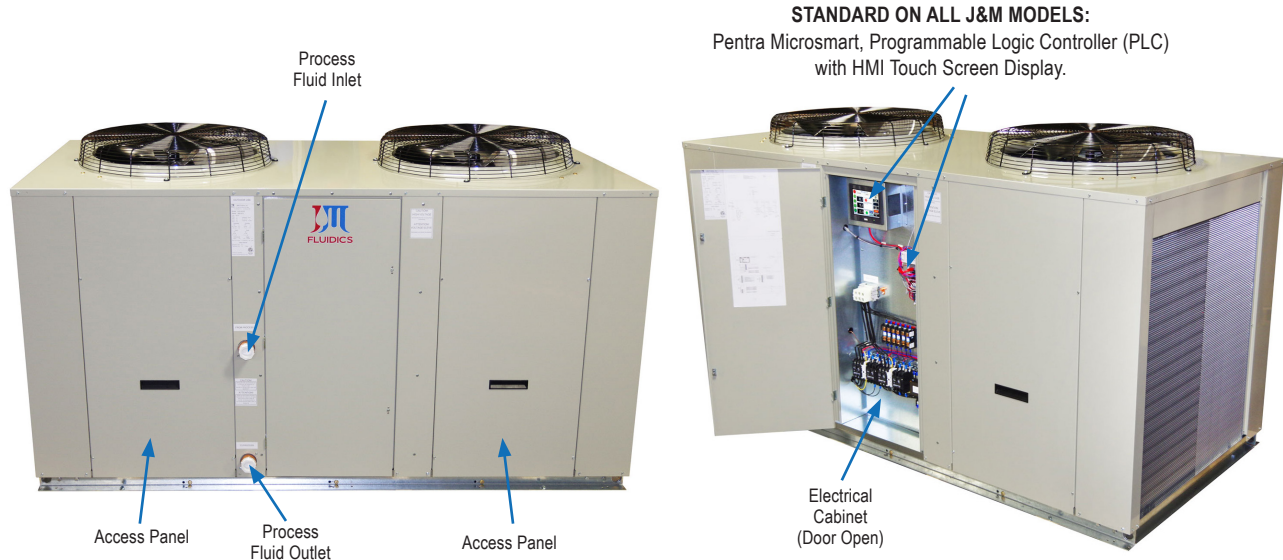

Standard Features:

- ETL listed to UL1995 & CAN/CSA C22.2 No. 236-11, 4th edition, 10/14/2011
- Single point power connection
- Pentra Microsmart, Programmable Logic Controller (PLC) with easy to use HMI touch screen display
- STAINLESS STEEL, brazed plate evaporator
- Scroll compressor with crankcase heater
- Suction accumulator
- Water flow switch
- Hot gas by-pass capacity control
- 24V control transformer
- Direct drive condenser fan motor
- Rust resistant, high CFM, aluminum condenser fan blade
- Condenser(s): copper tube/aluminum fin
- Compressor motor contactor
- Condenser motor and control circuit fusing
- Painted (Powder Coated), galvanized sheet metal cabinet
- 1/2" insulation on all water and Low pressure refrigerant lines
- Liquid line drier, sight glass, solenoid, TXV
- Complete refrigerant charge from factor
- **Factory Performance Test prior to shipment**



Options:

- Copeland Digital Scroll Compressor (*Hot Gas Bypass Removed*)
- Remote Idec touchscreen control panel
- Industrial VPN Router
- 5 Port Ethernet Switch
- BacNet Gateway
- STAINLESS STEEL Process Pump
- Process Pump VFD Controller
- VFD Compressor Control (*Hot Gas Bypass Removed*)
- 4 year extended compressor warranty
- Casters (factory mounted)
- 115 volt (rain tight) service outlet
- Non Fused Disconnect
- Phase/voltage monitor
- Compressor fusing
- Compressor Sound Cover
- Flooded cond. w/receiver/head pressure control (0°F)
- Flooded cond. w/**Heated** receiver/head pressure control (-20°F)
- Dual process pumps with auto changeover
- Pump suction isolation valve(s)
- Water pressure gauge set
- Copper finned condenser coil (coastal protection)
- Coastal powder coat paint protection
- E-Coat Condenser Coil (coastal protection)
- Water Flow Meter
- Auto city water changeover panel with filter
- Door Mounted HMI with weather proof cover



*Easy to Use
Touch Screen Display
on ALL J&M Chiller
Models*

J&M FLUIDICS, INC. – PRODUCT DATA SHEET



It's All about Building a Better Product for Our Clients!

J&M Fluidics, Inc.

851 Tech Drive
Telford, PA 18969

Toll-Free: (888) 539-1731

Fax: 267-203-8786

Model: PZA15D

Packaged Air-Cooled 15 Ton Chiller

Product Dimensional Drawing

© Property of J&M Fluidics, Inc.

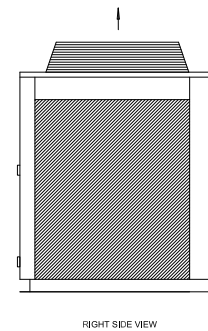
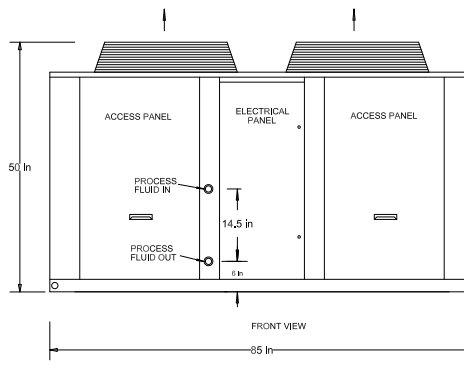
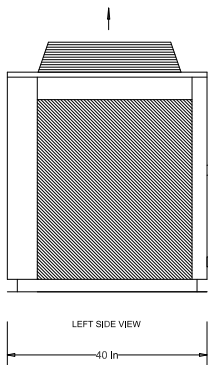
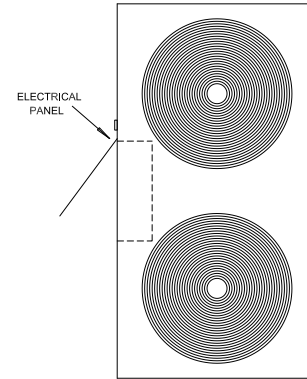
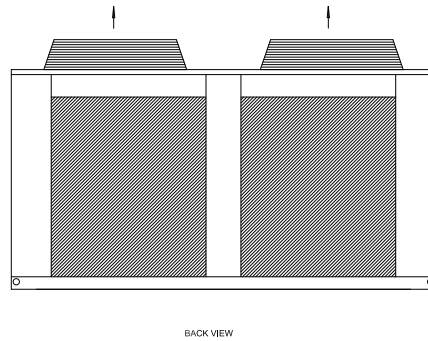
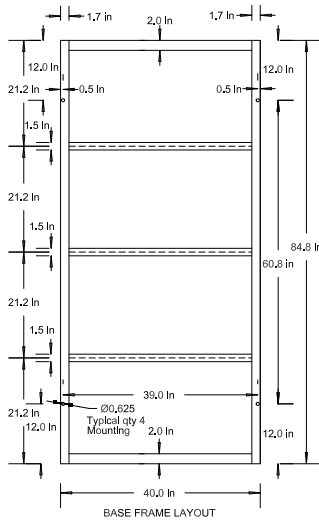

Dimensional & Electrical Table (Dual Circuit)

Chiller Models	Length Inches	Width Inches	Height Inches	Power			Compressor		RLA ea.	LRA ea.	Fan Motor		MCA	M.O.P.	Chiller Fluid Conn.	Weight Pounds
				Voltage	Phase	Freq.	Qty.	HP			Qty.	FLA.				
PZA15DF6	85	40	50	208/230V	3	60Hz	2	9	30.1	225	2	3.8	80	100	1.25" FPT	1000
PZA15DH5				460V	3	60Hz			15.5	114		1.5	40	50		
PZA15DI5				575V	3	60Hz			12.1	80		1.72	35	40		

Capacity Table (Refrigerant R407C)

Model	Compressor	LWT °F	80°F			90°F			95°F			100°F			105°F		
			TONS	KW	EER	TONS	KW	EER	TONS	KW	EER	TONS	KW	EER	TONS	KW	EER
15D	ZB66KCE	42.0	15.3	14.0	11.8	14.6	15.5	10.3	14.3	16.2	9.7	13.9	17.1	9.0	13.5	17.9	8.4
		44.0	16.3	14.3	12.3	15.5	15.7	10.8	15.2	16.5	10.1	14.8	17.3	9.4	14.5	18.2	8.8
		45.0	16.5	14.4	12.5	15.8	15.8	10.9	15.5	16.6	10.3	15.2	17.4	9.6	14.8	18.3	8.9
		50.0	17.8	14.8	13.2	17.1	16.2	11.6	16.8	17.0	10.8	16.4	17.8	10.2	16.0	18.7	9.5

- Capacities on this chart are based on refrigerant R407C. Lower leaving water or low ambient can require the use of a glycol solution or other fluid blends. These solutions affect unit capacities. Please consult the factory on these or other special fluids.
- KW input is for compressor(s) only.
- EER = Energy Efficiency Ratio (BTU/watt-hour). Power inputs include compressor (s), condenser fan motor (s) and control power.