



*It's All about Building a
Better Product for Our Clients!*

J&M Fluidics, Inc.
851 Tech Drive
Telford, PA 18969
Toll-Free: (888) 539-1731
Fax: 267-203-8786

Model: RRT1000

1000 Gallon Process Tank & Pump Package



(Polyethylene Tank)
Standard Features:

- Open Vented **1000 gallon Polyethylene tank**
- 1/2" tank and fluid piping insulation
- Copper & Polypropylene piping
- Fused, **STAINLESS STEEL** evaporator recirculating pump
- Recirculation pump discharge ball valve and cleanable "Y" strainer
- Control box with pump terminal block
- Galvanized steel sheet metal cabinet
- Hinged removable access panels

Available Options:

- Fused, **STAINLESS STEEL** process pump
- Dual process pump with manual changeover
- Dual process pump with auto changeover
- Pump suction isolation valve
- **Process Pump VFD Controller**
- **Tank fluid sight glass**
- Tank liquid level indicator with dry contacts
- Low flow by-pass valve
- **Water flow meter**
- Auto city water make up solenoid
- 1" tank and piping insulation in lieu of 1/2"
- Seal-tight electrical conduit and connections
- **Painted - Powder Coated**



J&M FLUIDICS, INC. – PRODUCT DATA SHEET



It's All about Building a Better Product for Our Clients!

J&M Fluidics, Inc.

851 Tech Drive
Telford, PA 18969

Toll-Free: (888) 539-1731

Fax: 267-203-8786

Model: RRT1000

1000 Gallon Process Tank & Pump Package

Product Dimensional Drawing

© Property of J&M Fluidics, Inc.

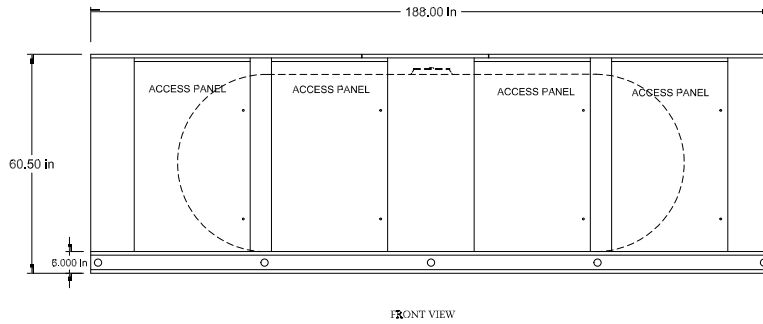

FRONT VIEW

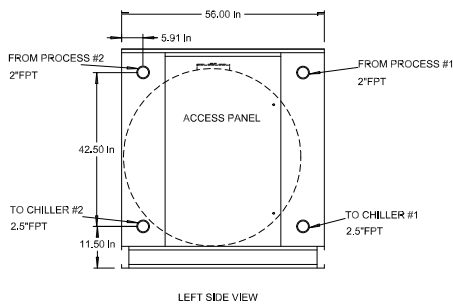

LEFT SIDE VIEW

*Drawing Shown with Optional (2) in from Process and (2) out to Chiller

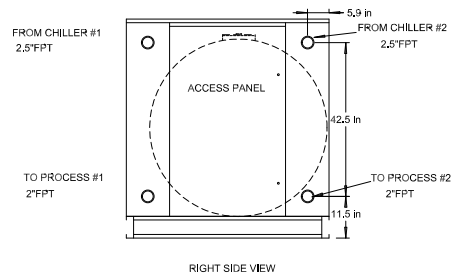

RIGHT SIDE VIEW

Polyethylene Tank & Pump

Tank Model	Length Inches	Width Inches	Height Inches	Water Conn.	Tank Capacity	Recirculation Pump	FLA 230/3Ø	FLA 460/3Ø	Weight Lbs.
RRT1000	180	56	60.5	2.5" FPT	1000 Gallons	7.5 HP	NA	9.1	2500

J&M FLUIDICS, INC. – PRODUCT DATA SHEET